

AM-708E

DESKTOP TYPE COMPRESSOR MICROPHONE
(W/NON-MODULATION PREVENTION CIRCUIT)

SPECIFICATIONS

-
- Microphone ----- High Sensitivity Electret Condenser Mic. Element 1pcs.
 - IC ----- 2pcs.
 - Transistor ----- 20pcs.
 - Diode ----- 13pcs.
 - Compressor Level ----- HIGH :45 dB, LOW : 35 dB
 - Output Voltage ----- COMP:0-30mV(RMS) MANUAL:0-70mV(RMS)
 - Matching Outputs Impedance ----- 500Ω-100KΩ
 - Power Voltage ----- Battery : DC3V(UM3×2 pcs.)
Mic. Cable "D" series ----- DC5-9V
 - Current Consumption ----- at Receiving: 3mA, Transmitting: 6mA(approx)
 - Alarm Sound ----- approx. 4.5KHz Intermittent Tone
 - Flexible(Gooseneck)Pipe ----- ϕ 8mm, (Length: 150mm)
 - External Size ----- 182 (W) × 130 (D) × 322 (H)mm
 - Weight ----- approx. 830 g.
-

DESKTOP MICROPHONE MODEL **AM-708E** INSTRUCTIONS

Thank you very much for your Purchase of "ADONIS" Desktop Microphone Model AM-708E. To enjoy this unit satisfactorily, please read the instructions carefully and we hope you can enjoy this microphone for a long time.

FEATURES:

- o Selectable for 2 sets of transceivers at once by slide switch.
- o High Sensitivity Electret Condenser Microphone Element equipped.
- o High Quality Compressor Amplifier (High-Low selectable) built-in. It sends out always constant and optimum level without distortion regardless of audio input level.
- o Equipped with FM/SSB Audio Quality Selector Switch for optimum operation.
- o Non-Modulation Prevention Circuit built-in.

After continuous transmitting for a few minutes, the alarm circuit will be activated with alarm sound for 30 seconds. Then, the condition returns to receiving mode automatically.

- o Battery-Check Circuit built-in.

Turn the power switch on (by selecting "FM" or "SSB" position), and, the level meter indicates the battery condition with power voltage for a few seconds.

- o Connectable with the microphone interconnecting cable provided with power feeding line. (Adonis terminal arrangement indicates it as 'B' in the center of connector.)

You can choose the power source from dry batteries (UM3 × 2) or transceiver (microphone connector DC5 - 9V/20mA minimum).

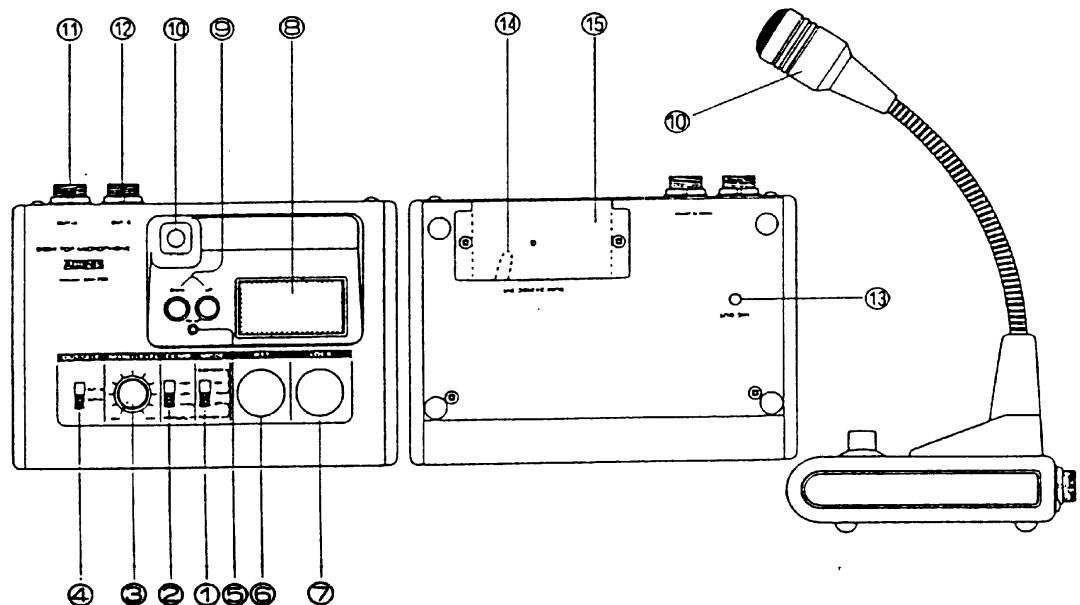
CONTROLS(Front Panel and Rear Side): (Fig. 1)

- 1) "Power" and "FM/SSB" (Battery Check) Audio Quality Selector Switch

Set the Power Switch① to "FM" or "SSB" position for the power "ON", and, the Level Meter⑧ indicates the battery condition. A little while later, the level meter will return to its original function of level meter.

It gives optimum audio quality for both FM and SSB modes by changing the frequency characteristics, in particular, it is effective in DX operation.

(HOW to check the battery)

Turn the power switch① "ON", then, the pointer deflects and stops for a few seconds. If the pointer stops at the outside of green-zone, replace the battery to new one.

- 2) Compressor Level Selector Switch
- o HIGH (45dB) : Select this position when you speak in a low voice or away from the microphone in a quiet place.(The microphone will pick up the noise around the microphone.)
 - o LOW (35dB) : This is optimum position for normal QSO. You can enjoy QSO with enough voice level at 10cm away from microphone.
 - o MANUAL : Select this position when you operate at noisy area or when you do not want to use compressor function. The compressor Level Volume③ will be activated.
- 3) Manual Level Volume : It will be activated when the Compressor Level Selector Switch② is at "Manual" position. Adjust it to get an optimum level. (The pointer of level meter should not deflect over "0dB".)
- 4) Output Selector : A changeover switch to select "OUT-A" ⑪ or "OUT-B" ⑫.
- 5) "ON AIR" Indicator : Turn the power switch① "ON" and LED Indicator ⑤ will blink on and off to indicate the receiving condition.
The LED⑤ will light up continuously when transmitting.
- 6) PTT Switch : Use it for short time QSO. While pressing it, the TX LED indicator lights up and the condition is transmitting. (When press it, it sounds 'pip' When releasing the LOCK condition, also press this switch.)
- 7) LOCK Switch : Use it for long time QSO. Press it and it sounds 'peep' .
The LED TX indicator⑤ will light up continuously. The condition is transmitting until pressing the PTT switch⑥.
- 8) Level Meter : You can watch the level of microphone amplifier with this meter. When you use this microphone with "MANUAL" position of Compressor Level Selector Switch, you will have to adjust the indicator of the meter to keep under"0dB". Refer to Manual Level volume③
And it works as battery checker for a few seconds just after switching the power "ON" .
- 9) UP/DOWN Switch : The same function as the UP/DOWN switch of transceiver. For details, please read the instruction book of transceiver.
- 10) Microphone : This model is provided with Electret Condenser type microphone for easy understanding sound quality.
- 11) Mic. Output Connector: "OUT-A"(8P ADONIS type terminal arrangement)
- 12) Mic. Output Connector: "OUT-B"(8P ADONIS type terminal arrangement)

(Note: The microphone Interconnecting Cables optionally available are provided with directional condition for connecting. Please connect the cable with microphone correctly.)

Terminals of Microphone Output Connector and ⑪ & ⑫ and "ADONIS" standard terminal layout (8P)

(Fig. 2)

- ① E : MIC.EARTH
- ② M : MIC
- ③ P : PRESS TO TALK
- ④ G : PRESS TO TALK (EARTH)
- ⑤ U : UP
- ⑥ D : DOWN
- ⑦ C : U/D COMMON
- ⑧ B : DC FEEDING (DIRECT CURRENT) (VIEWED FROM TERMINAL PIN SIDE)

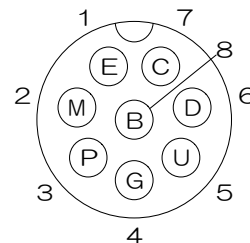

* When the transceiver connected to this model is supplying the microphone terminal with DC5V-9V, 20mA minimum current, this model can get the DC power supply directly from transceiver by connecting with "D" series microphone interconnecting cables. For details, please refer to the list of the microphone interconnecting cables optionally available.

13) Output Adjustment Volume : Adjustment Volume for output voltage. It is factory-present at the optimum level. When the modulation level is not acceptable to you, please adjust this volume to have optimum level.

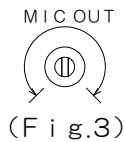

(Please adjust under the "HIGH" position of Compressor Level Selector Switch.) The Output is increased by rotating the volume(13) clockwise. Please adjust with 2mm wide screw driver carefully and slowly under monitoring by local station. (It is relatable 90° for both left and right from center position.) The Figure No. 3 shows the center position.

14) The Leadwire releasing for the Non-Modulation Prevention Circuit.

15) Battery Cover : When operating with battery, remove the 2 set screws of rear side(bottom plate) and set the batteries (2 × UM3) correctly. The batteries are not provided with this microphone.

(Optional Accessories : External Power Supply Adaptor model PS3 will enable you to use with DC13.8V external power supply unit. Please note.)

NON-M:ODULATION PREVENTION CIRCUIT:

When the transmitting condition continues for 2-3 minutes, the alarm circuits will be activated with sounding the alarm for 30 seconds. Then, the condition will return to the receiving condition automatically.

(Timer Reset Function)

When using the microphone with "LOCK"(continuous transmitting), press the "LOCK" switch again and the timer for alarm will be reset and the timer again starts for counting. When sounding the alarm, the alarm will stop by pressing "LOCK" switch.

CANCELLING OF NON-MODLTATION PREVENTION CIRCUIT:

Remove the battery cover(15) and cut off the leadwire (14) yellow which is the wire for canceling the Non-Modulation Prevention Circuit. After cutting, please be sure to cover the wires (tip of wire) with insulation tape.

COMPRESSOR AMPLIFIER FUNCTION:

Compressor Amplifier serves constant distortionless output level regardless of the audio input level conditions. In other words, depending on the audio input level, electrical volume control is automatically made. Please refer to the sketch below. The input levels from 'a' to 'b' are linearly amplified and from 'b' to 'c' are compressed. The compressor level means the voltage ratio of input levels at 'b' and 'c'. For example, at compressor "HIGH", compressor area includes from 1mV and it has 45dB compressor Level

(F i g. 4)

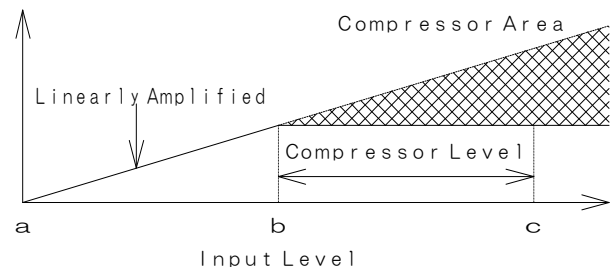

minimum. So, you can send out the constant output level regardless voice, whispering, small or loud. By the constant output level, you can extend the communication distance by using rated output power of transceiver without any loss. So, now it becomes common to use compressor amplifier between transceiver and microphone.

CAUTIONS :

- Please be sure to use "ADONIS" Interconnecting Cables separately available. Please refer to the list of Microphone Cables.
- When supplying the power from transceiver with "D" type mic. cables, the batteries set to the microphone do not send the power to microphone, but, after switching the power of transceiver "OFF" , the batteries in the microphone will be activated automatically. Please be careful about it. Please be sure to turn the power switch "OFF" after QS0.
- When using external adaptor for power supply from DC13.8V, please be sure to use PS-3 optionally available.
- Please be careful about high SWR of antenna and incomplete earthing, since it may cause the trouble of RF Feedback noise depending on coaxial cable layout.
- Do not place the microphone near high temperature area or under direct sunlight.